

Caratteristiche unità di sabbiatura

Autonomia 60 lt

Ugelli in widia disponibili diametro

03/04/05/06 mm

Scuotitore pneumatico

Miscelatore pneumatico

Riduttore di pressione

Silenziatore di scarico pressione

Ciclone per la separazione delle polveri

Dimensioni

A 470 mm B 1600 mm C 675 mm D 600

Peso kg 104

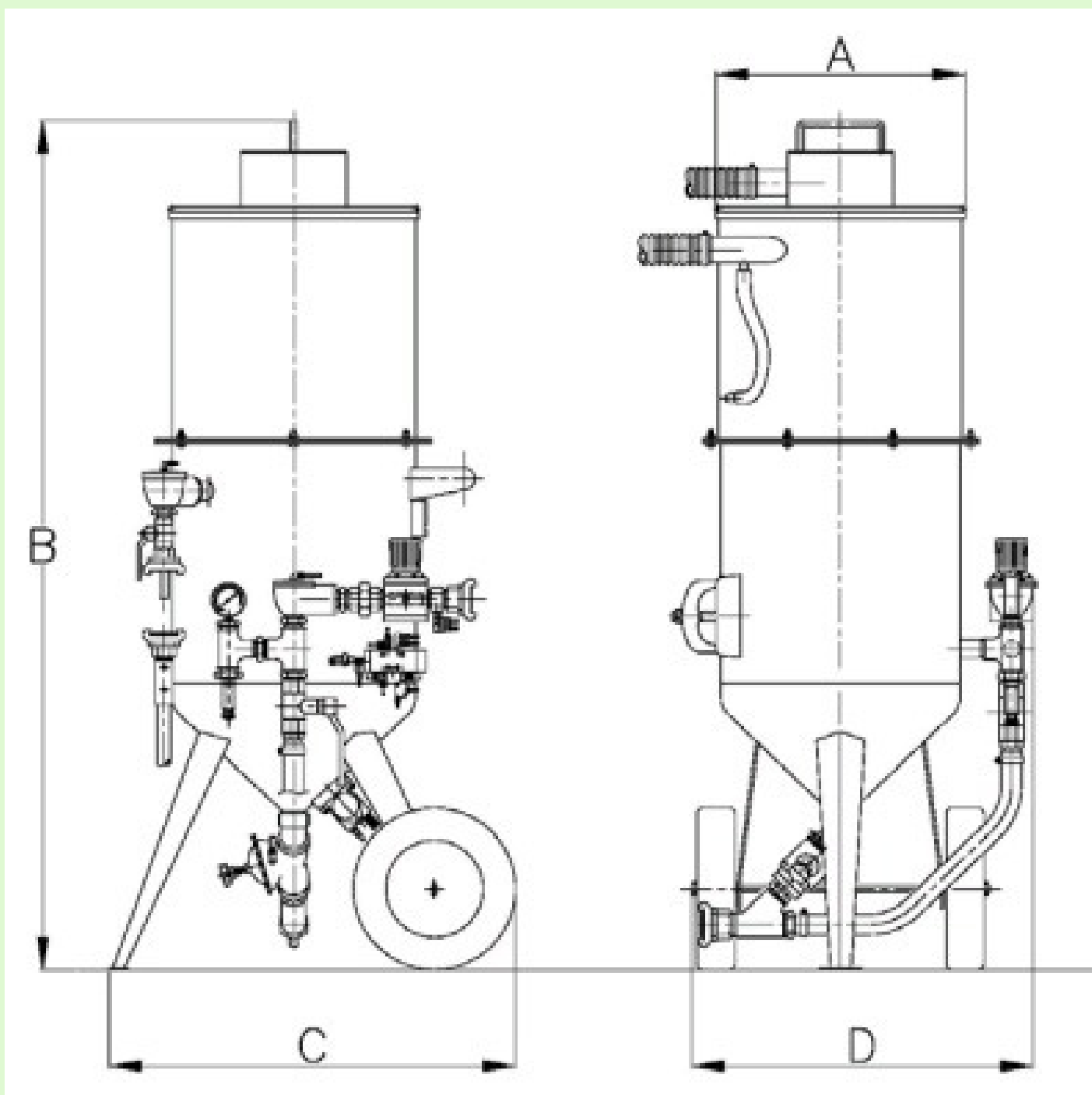

Caratteristiche unità di aspirazione

Potenza 03 kw

Tensione 230+ 400V-3P+N+T

Portata d'aria m³/h 320

Depressione max 320 mBbar

Capienza 70 lt

Dimensioni 80 x 60 x H 162 cm



PRESSURE BLASTER TOP VERSION

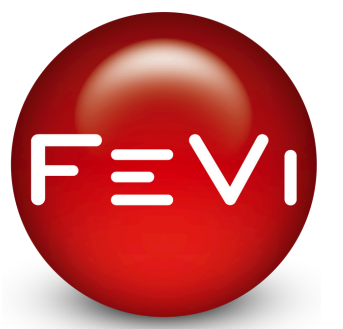

Sandblasting unit characteristics

Autonomy 60 lt.

Tungsten Carbide Nozzles Available
with Diameters 03/04/05/06 mm

Pneumatic Shaker

Pneumatic Mixer

Pressure Reducer

Pressure Exhaust Silencer

Cyclone for Dust Separation

Dimensions

A 470 mm B 1600 mm C 675 mm D 600

Weight kg 104

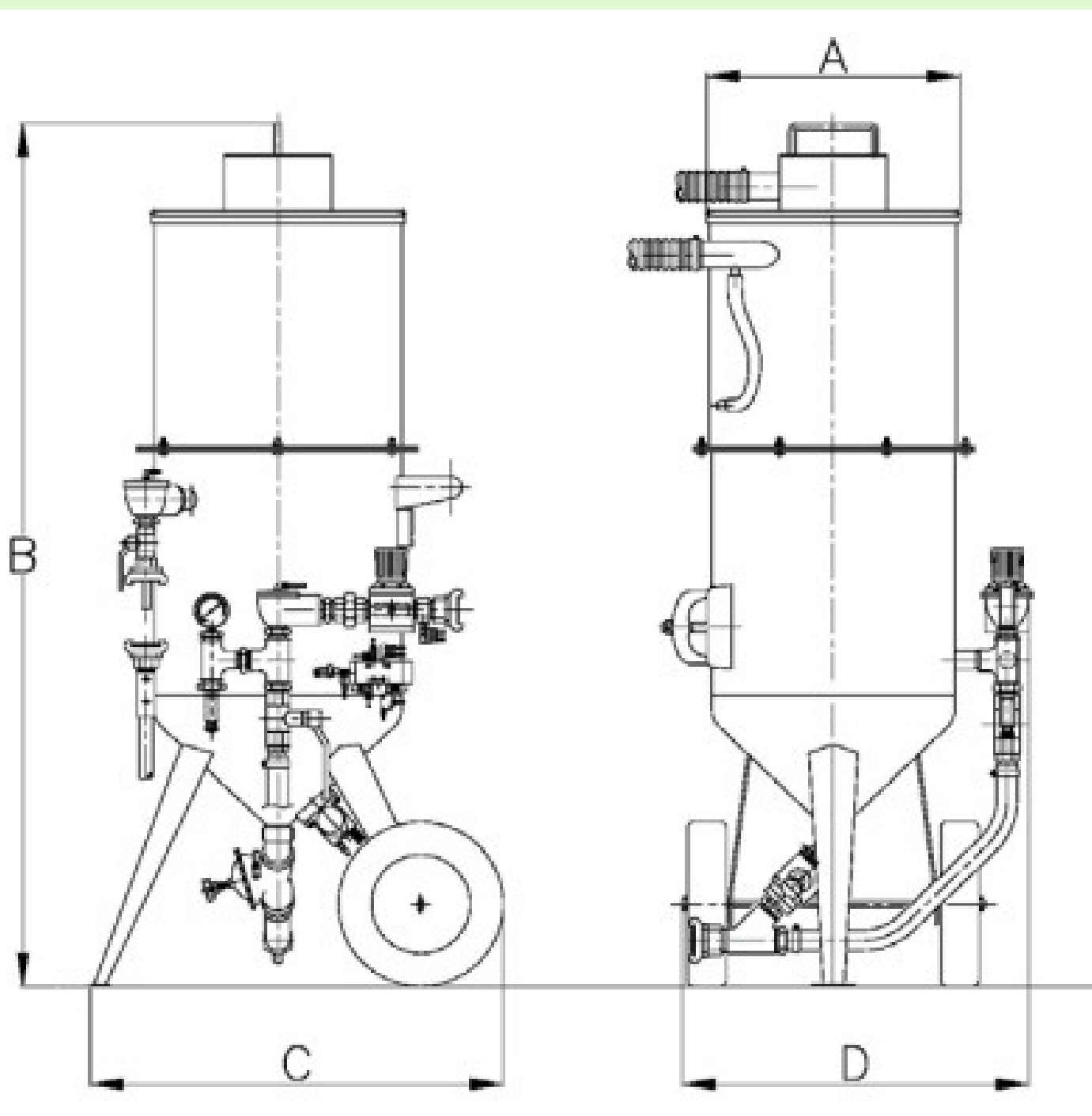

Suction unit characteristics

Strength 03 kw

Tension 230+ 400V-3P+N+T

Airflow m³/h 320

Depression max 320 mBbar

Capacity 70 lt.

Dimensions 80 x 60 x H 162 cm

